

High Pressure First Stage Regulators

LV4403SR and TR Series

Application

Provides accurate first stage regulation in two-stage bulk tank systems. These regulators handle vaporization of tanks up to 1200 gallons. Reduce tank pressure to an intermediate pressure of 5 to 10 PSIG. Also used to supply high pressure burners for applications like industrial furnaces or boilers. Also incorporated in multiple cylinder installations.

Features

- Incorporate integral relief valves for added system protection.
- Large vent helps prevent blockage and has 3/4" F.NPT thread for vent piping.
- Bonnet vent positioned over outlet to avoid icing and contamination by foreign material.
- Unique bonnet vent profile designed to minimize vent freeze over when properly installed.
- Replaceable valve orifice and valve seat disc.
- Straight-line valve closure reduces wear on seat disc.
- Large molded diaphragm is extra sensitive to pressure changes.
- Built in pressure tap has plugged 1/8" F.NPT outlet. Plug can be removed with a 3/16" hex allen wrench.
- Extra long lever arm provides uniform delivery pressure.
- Brilliant red finish.

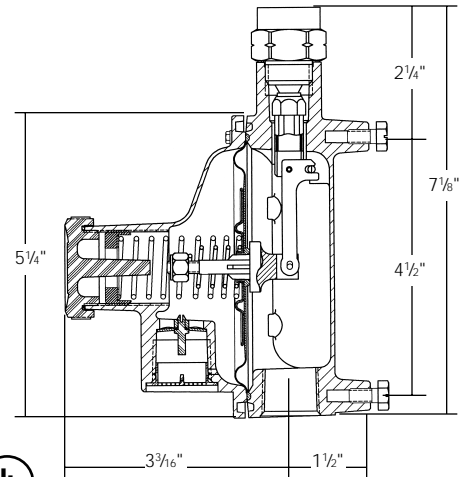

Materials

Body	Die Cast Zinc
Bonnet	Die Cast Zinc
Nozzle Orifice	Brass
Spring	Steel
Valve Seat Disc	Resilient Rubber
Diaphragm	Integrated Fabric and Synthetic Rubber

Ordering Information

Part Number	Inlet Connection	Outlet Connection	Orifice Size	Factory Delivery Pressure (PSIG)	Adjustment Range* (PSIG)	Integral Relief Included	Vapor Capacity BTU/hr. Propane**
LV4403SR4	1/2" F. NPT	1/2" F. NPT	1/4"	5	1-5	Yes	2,500,000
LV4403TR4				10	5-10		
LV4403SR9	F. POL			5	1-5		
LV4403TR9				10	5-10		
LV4403SR96	3/4" F. NPT	5		1-5			
LV4403TR96		10		5-10			

* When used for final stage pressure control, must either incorporate integral relief valve or separate relief valve should be specified in accordance with NFPA Pamphlet 58.

** Maximum flow based on inlet pressure 20 PSIG higher than the regulator setting and delivery pressure 20% lower than the setting.

LV4403SR

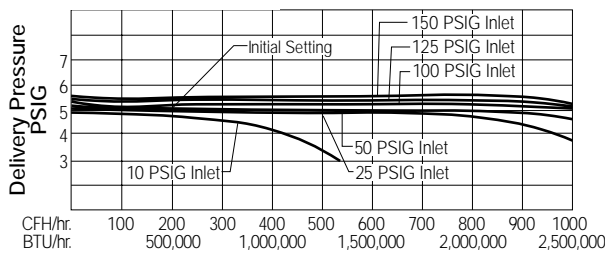

LV4403TR

